

A Review of Principle Analysis and Control Strategy Based on Single-phased Photovoltaic Inverter's Topological Structure

Jixin Shao

School of Energy and Materials, Shihezi University, Shihezi, China

13960985622@139.com

Abstract: The new power system is the organic carrier to realize the high-quality development of energy, and the photovoltaic inverter, as a new type of power electronic equipment, can promote the realization of low-carbon energy transformation and the sustainable development of economic society. With the large-scale and high proportion of photovoltaic inverters connected to the grid and becoming the main body of electricity supply, higher requirements are put forward for the flexibility of the new power system grid. Combined with the control strategy, this paper analyzes the principle of the existing typical single-phased photovoltaic inverters, exploring the future research direction of inverters and DC converters and prospecting the application of photovoltaic equipment in the new electric power system in the future. This paper not only enriches the research theory of single-phase photovoltaic inverters, but also provides reference and help for further research on photovoltaic inverters.

Keywords: photovoltaic inverter, DC converter, topological structure, control strategy, new electric power system

1. Introduction

Under the goal of carbon peaking and carbon neutrality, new energy will gradually replace the dominant position of traditional fossil energy in the energy system. In the future, new energy will become the main provider of electric power, and will also have the ability to actively support. With the strong support of the policy, the research and development of photovoltaic inverters and DC converters has become a hot spot. In the system of photovoltaic power generation, DC converters serve as an important intermediate bridge, which can convert the input DC voltage into the desired DC output voltage. At the same time, through efficient switching modulation technology, more than 90% of the energy conversion efficiency can be achieved, thereby reducing the power consumption of the equipment and extending the service life. As an essential component in the grid-connected process, the stability of a photovoltaic inverter and the high-quality power it provides has become the focus of research. The research on photovoltaic inverters and DC converters mainly focuses on four aspects: topological structure, filter technology, control strategy and maximum power point tracking technology [1-2]. This paper reviews the current single-phase photovoltaic inverter topology, expanding its working principle, analyzing the feasibility and effectiveness of the topology, and sorting out the advantages and disadvantages of the current inverter control strategy. Finally, the future application of the photovoltaic inverters and DC converters in the electrical power system is

prospected. This paper provides a reference for the improvement of inverter topology and the further study of inverter control strategy.

2. Voltage source type single phase full bridge photovoltaic inverter

2.1. Problems in voltage source-type single-phase full-bridge photovoltaic inverters

The surface of the single-phase photovoltaic inverter is wrapped by a metal shell, the insulator and the metal shell are filled with glass media, resulting in a parasitic capacitance effect. Therefore, the full-bridge inverter structure can be equivalent to a parasitic capacitor side and the power grid side, in between the photovoltaic source, direct current capacitance, converter, filter, and power grid, composed of an overall structure. Because the full-bridge inverter adopts pulse width modulation, the four switching tubes of the full-bridge inverter have four kinds of conduction modes, and the voltage difference between the two terminals of the equivalent parasitic capacitance will be generated during the switching process of the four conduction modes and a leakage current will be generated at both ends of the parasitic capacitor at this time and injected into the inverter. Due to the existence of a leakage current, the photovoltaic system will have the following three adverse consequences: First, in the photovoltaic system, the existence of the inverter leakage current will lead to increased power loss, the system temperature too high, and then shortened life of the photovoltaic module and reduce the efficiency of the system, which will cause the system to collapse. Second, from a security perspective, inverter leakage flows constitute a great threat to the safety of the maintenance staff; they may lead to electric shock damage. Third, from the angle of the equipment, the leakage flow intensifies the aging of the photovoltaic panels. Once the panel is damaged, the internal chemical may leak, damaging the environment. In order to avoid the adverse effects caused by leakage current, it is necessary to construct an open circuit structure between the parasitic capacitor and the power grid. For this reason, many literatures have respectively proposed the topology of the H5 full-bridge inverters and Heric full-bridge inverters. The aim is to keep the voltage at both ends of the parasitic capacitor constant under pulse width modulation. Thus, the leakage current of the inverter can be effectively suppressed [3-4]. The working principle of H5 and Heric full-bridge inverters is analyzed below.

2.2. Principle analysis of single-phase full-bridge photovoltaic inverter

2.2.1. Principle analysis of H5 full-bridge inverter

The H5 full bridge inverter consists of 5 switching tubes, 4 diodes, a DC capacitor and a DC power supply. According to the analysis of Figure 1, switches S1, S4 and S5 are closed, S2 and S3 are disconnected at this time, and the AC power supply is in the positive half-fundamental period. According to the selected reference direction in the figure, the following equations can be listed according to Kirchhoff's voltage law:

$$\begin{cases} -V_{PV} + V_{L1} + V_g + V_{L2} = 0 \\ -V_{PE} - V_{L2} = 0 \\ V_{L1} = V_{L2} \end{cases} \quad (1)$$

System of simultaneous equations can be solved:

$$V_{PE} = 0.5(V_g - V_{PV}) \quad (2)$$

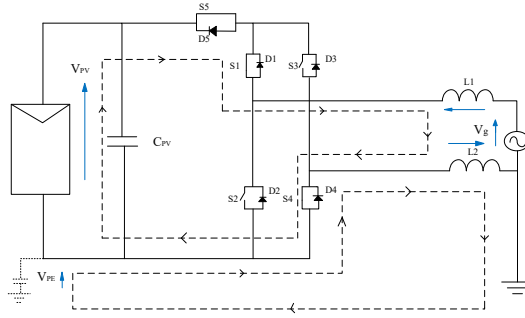

Figure 1: Ac power supply positive half-fundamental periodic operating mode 1

If the switch S5 is disconnected, the switches S2 and S4 are also disconnected, as shown in Figure 2. At this time, the connection between the DC side and the AC side of the power grid is cut off. Meanwhile, the power grid releases the stored energy through the loop composed of diode D3 and switch tube S1 until the energy is completely released. Since it does not form a loop, the voltage fluctuation at both ends of the parasitic capacitance is 0, therefore, there is no existing leakage current. At this point, the formula $V_{PE} = 0.5(V_g - V_{PV})$ still holds.

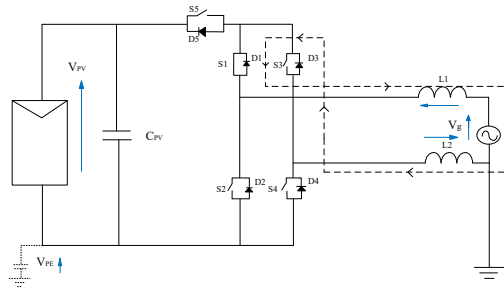

Figure 2: Ac power supply positive half-fundamental periodic operating mode 2

In the negative half period of the AC power supply, if the switch S5 is closed, the switches S1 and S4 are disconnected, and the switches S2 and S3 are closed, two circuit equations can be listed in the inverter circuit according to Kirchhoff's voltage law. The loop direction of the circuit equation is shown in Figure 3. Since the resistance values of the inductors L1 and L2 are equal, the following equations can be listed:

$$\begin{cases} -V_{PV} + V_{L2} - V_g + V_{L1} = 0 \\ -V_{PE} - V_{L1} + V_g = 0 \\ V_{L1} = V_{L2} \end{cases} \quad (3)$$

The equation can be solved by:

$$V_{PE} = 0.5(V_g - V_{PV}) \quad (4)$$

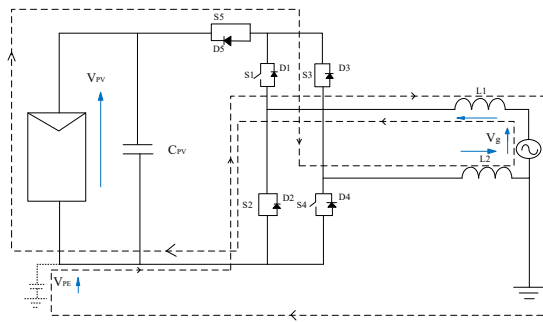

Figure 3: AC power supply negative half fundamental period operating mode 1

If the switch S5 is disconnected, it can be seen from Figure 2 that the DC side of the inverter is connected to the AC side of the power grid at this time, so there is no current flow path in the inverter loop, and there is no voltage difference between the two ends of the parasitic capacitor at this time. According to Figure 4, it can be seen that the inductive energy storage is released through the closed loop composed of diode D1 and switch tube S3 until the energy is completely released. The formula $V_{PE} = 0.5(V_g - V_{PV})$ still holds.

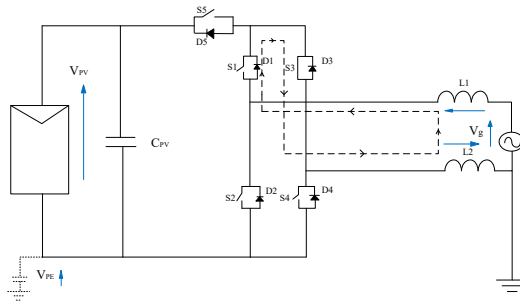

Figure 4: AC power supply negative half fundamental period operating mode 2

2.2.2. Principle analysis of HERIC full-bridge photovoltaic inverter

In order to solve the problem of leakage current, some scholars put forward the topology of the HERIC full-bridge inverter, which is composed of 6 switching tubes and 6 diodes. Switch tubes S1 and S4 are closed, while S2, S3, S5 and S6 are disconnected, as shown in Figure 5. At this time, according to the loop equation, it can be seen that the positive half-fundamental period working principle is the same as that of the H5 full-bridge inverter. The formula $V_{PE} = 0.5(V_g - V_{PV})$ about the voltage at both ends of the parasitic capacitor still holds.

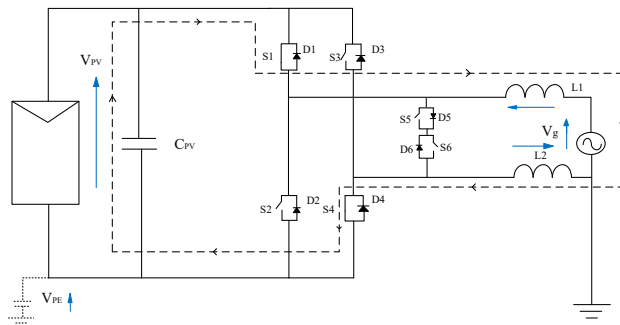

Figure 5: AC power supply positive half-fundamental periodic mode 1

When switches S1, S2, S3 and S4 are disconnected and S5 and S6 are closed, as shown in Figure 6, the DC side is cut off from the AC power grid side, and the energy stored in the inductor is released through the closed switch tube S5 and S6 until the energy is exhausted. At this time, the voltage at both ends of the parasitic capacitor does not fluctuate, so the leakage current does not exist. The formula $V_{PE} = 0.5(V_g - V_{PV})$ about the voltage at both ends of the parasitic capacitor still holds before and after the switch motion.

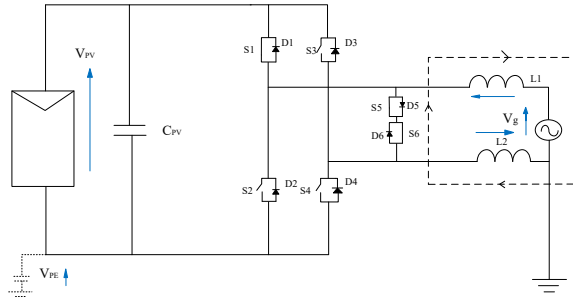

Figure 6: AC power supply positive half-fundamental periodic mode 2

For the state of the negative half-fundamental period of the AC power supply, if the switching tubes S1, S4, S5 and S6 are disconnected, and S2 and S3 are closed, as shown in Figure 7, the voltage equation of the HERIC photovoltaic inverter is the same as the H5 photovoltaic inverter shown in Figure 1.

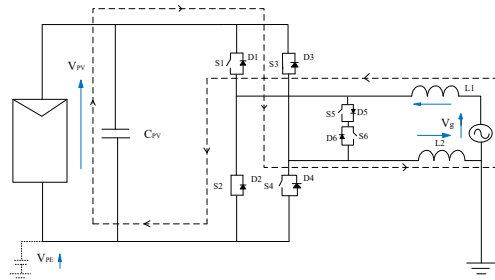

Figure 7: AC power supply negative half fundamental period operating mode 1

If the switch tube S5 and S6 are closed and S1, S2, S3 and S4 are disconnected, the inductive energy storage is completely released to the AC power grid through the switch tube S5 and S6, as shown in Figure 8.

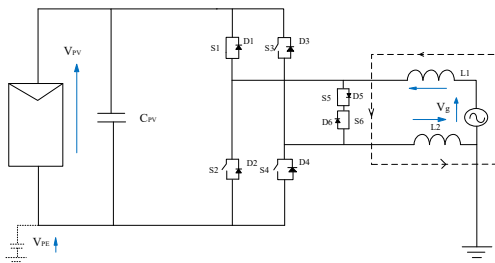

Figure 8: AC power supply negative half fundamental period operating mode 2

2.2.3. Principle analysis of NPC three-level photovoltaic inverter

The working principle of an NPC inverter is different from that of H5 and HERIC inverters. It is to prevent leakage current by selecting the capacitor midpoint of the DC terminal of the inverter as the

zero potential point, and then fixing the output voltage of the inverter and the voltage at both ends of the parasitic capacitor [5]. The topology of the NPC inverter is composed of 4 switching tubes and 6 diodes. When the AC power supply is in the positive half cycle, the diodes D5 and D6, and switching tubes S3 and S4 are disconnected, and S1 and S2 are switched on, as shown in Figure 9. According to the loop reference direction, the equations can be listed as follows:

$$\begin{cases} -V_{PV}/2 + V_{AB} = 0 \\ -V_{PE} - V_{PV}/2 = 0 \end{cases} \quad (5)$$

It can be solved:

$$\begin{cases} V_{AB} = V_{PV}/2 \\ V_{PE} = -V_{PV}/2 \end{cases} \quad (6)$$

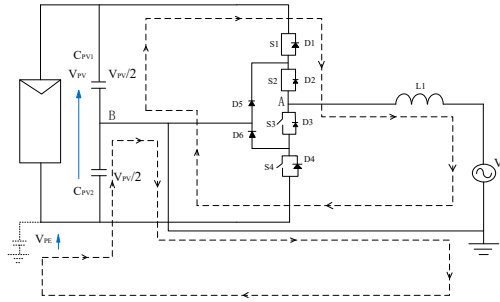

Figure 9: Ac power supply positive half-fundamental periodic operating mode 1

In the positive half fundamental period of the AC power supply, if the switching tubes S1, S3, and S4 is disconnected, and S2 is closed, then the inductor will completely release the stored energy through the diode D5. At this time, D5 and S2 are connected between two points A and B, so the two points A and B are short-circuited, $V_{AB}=0$, but due to the effect of the voltage clamp at the midpoint of the capacitor, the formula $V_{PE}=-V_{PV}/2$ still holds, as shown in Figure 10. Therefore, the voltage at both ends of the parasitic capacitor does not jump, and the leakage current is not generated.

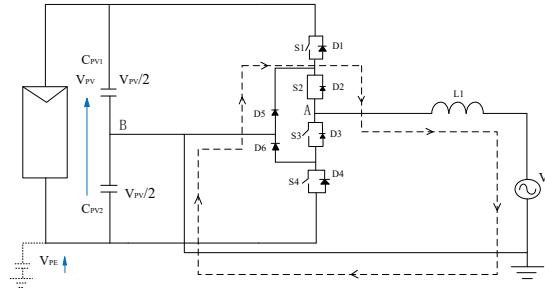

Figure 10: AC power supply positive half-fundamental periodic mode 2

In the negative half cycle of the AC power supply, the switch tubes S1 and S2 are not conducted, while S3 and S4 are conducted. The loop circuit is shown in Figure 11. According to the loop reference direction, the equations can be listed as follows:

$$\begin{cases} -V_{PV}/2 - V_{AB} = 0 \\ -V_{PE} - V_{PV}/2 = 0 \end{cases} \quad (7)$$

It can be solved:

$$\begin{cases} V_{AB} = -V_{PV}/2 \\ V_{PE} = -V_{PV}/2 \end{cases} \quad (8)$$

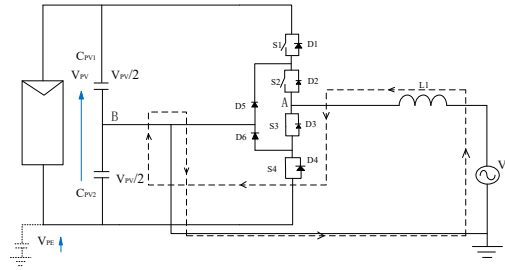

Figure 11: AC power supply negative half fundamental period operating mode 1

If S1, S2, and S4 are disconnected and S3 is closed, as shown in Figure 12, the negative half fundamental period inductance of the AC power supply releases energy through the switching tube S3 and diode D6. Since two points A and B are connected by an A wire, the output voltage $V_{AB}=0$ between two points A and B, and the voltage at both ends of the parasitic capacitor is not affected. Therefore, there is no leakage current.

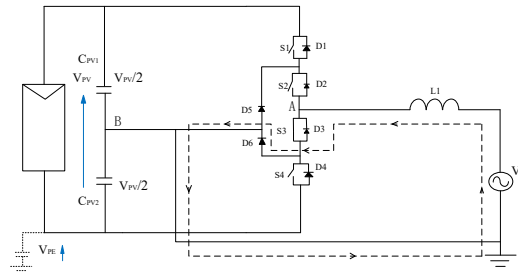

Figure 12: AC power supply negative half fundamental period operating mode 2

According to the output voltage of NPC inverter:

$$\begin{cases} V_{AB} = V_{PV}/2 & S1, S2 \text{ On}, S3, S4 \text{ Off} \\ V_{AB} = 0 & S1, S4 \text{ Off}, S2, S3 \text{ On} \\ V_{AB} = -V_{PV}/2 & S1, S2 \text{ Off}, S3, S4 \text{ On} \end{cases} \quad (9)$$

It is concerned that the on-state of switch tubes S1 and S3 are always opposite to S2 and S4, so two high-frequency in-phase triangle waves or 180° out-of-phase triangle waves are modulated with a low-frequency sine wave, so that two different signals are given to the switch tubes with opposite on-state, so as to achieve the above output three-level.

2.2.4. Principle analysis of T-type photovoltaic inverter

The T-type photovoltaic inverter has the advantage of multiple output levels, which can reduce losses and decrease the volume of the converter [6]. As shown in Figure 13, in the positive half cycle of the AC power supply, switches S2, S3, and S4 are disconnected, and S1 is closed, and the circuit equations can be listed as follows:

$$\begin{cases} -V_{PV}/2 + V_{AB} = 0 \\ -V_{PE} - V_{PV}/2 = 0 \end{cases} \quad (10)$$

It can be solved:

$$\begin{cases} V_{AB} = V_{PV}/2 \\ V_{PE} = -V_{PV}/2 \end{cases} \quad (11)$$

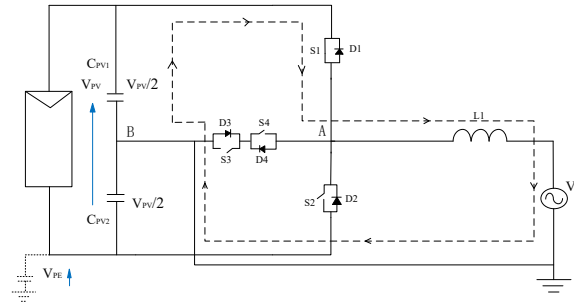

Figure 13: AC power supply positive half-fundamental periodic mode 1

In the positive half-fundamental period of the AC power supply, if the switching tubes S1 and S2 are disconnected and S3 and S4 are closed, the energy released by the inductor is completely released through the closed loop of the on-enabled S3 and S4 switching tubes. As shown in Figure 14, at this time, due to the conduction state of S3 and S4 between A and B, A and B is a short circuit, the output voltage V_{AB} is 0, and at the ends of the parasitic capacitance-voltage the formula $V_{PE} = -V_{PV}/2$ still remains. Therefore, no voltage jump happens on both ends of the parasitic capacitance, and no leakage current is generated.

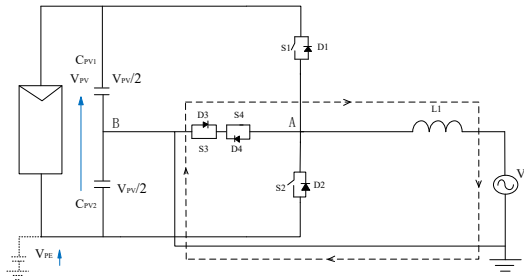

Figure 14: AC power supply positive half-fundamental periodic mode 2

In the negative half fundamental period of AC power supply, if switches S1, S3 and S4 are disconnected and S2 is closed, as shown in Figure 15, the equations can be obtained as follows:

$$\begin{cases} V_{AB} = -V_{PV}/2 \\ V_{PE} = -V_{PV}/2 \end{cases} \quad (12)$$

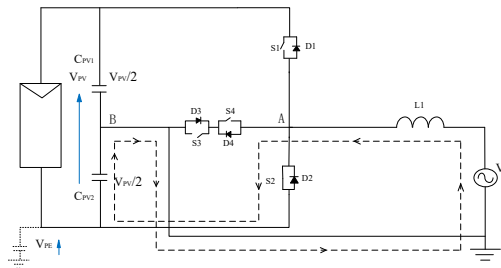

Figure 15: AC power supply negative half fundamental period operating mode 1

If switch S1 is disconnected and S2, S3 and S4 are closed, as shown in Figure 16, the following equation can be obtained:

$$\begin{cases} V_{AB} = 0 \\ V_{PE} = -V_{PV}/2 \end{cases} \quad (13)$$

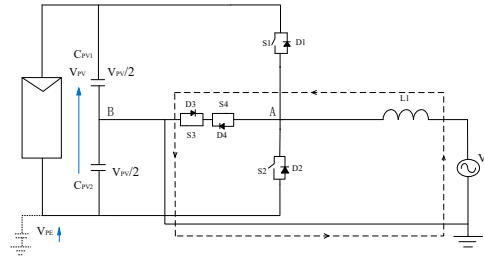

Figure 16: AC power supply negative half fundamental period operating mode 2

There is no voltage fluctuation at both ends of the parasitic capacitor, no leakage current is generated, and the output voltage of the T-Type inverter is consistent with that of the NPC inverter, and the control strategy is consistent with that of the NPC inverter.

3. Inverter maximum power point tracking method

Since the output power of the inverter is obviously affected by temperature, illumination and other factors, and it is hoped that the inverter can work in the state of maximum power point, this paper summarizes four common methods for the current maximum power point tracking of the inverter: Perturbation and observation method, incremental conductance method, fast global scanning algorithm, temperature measurement method, these four methods can achieve the maximum output power for the system under all radiation, temperature and other environmental conditions [2,7-9].

3.1. Perturbation and observation method

The core of the disturbance observation method is to further judge the direction of adjustment through the controller to increase or decrease the voltage in a small range and measure the corresponding output power through a known instant power point of the inverter. If the voltage is increased in a small range, it is found that the output power of the inverter increases, so the reference voltage should continue to be increased in the same direction until the immediate power reaches the maximum power point. This method is simple and easy to control, but the disadvantage is that the measurement of the maximum power point is not very accurate, which is easy to generate disturbance near the maximum power point, and the control speed is slow.

3.2. Incremental conductivity method

In order to find the maximum power point accurately, the incremental conductance method is introduced by the mathematical method. The output power of inverter $P = VI(V)$, in order to obtain maximum output power points, making a derivation of reference voltage on both ends of the equation is demanded, because the current is a function of voltage. Therefore, the right side of the equation takes the form of the derivative of a compound function in the process of derivation, it can be concluded that

$$\frac{dP}{dV} = I(V) + V \frac{dI(V)}{dV} \quad (14)$$

To make $\frac{dP}{dV}$ equals to zero, then the formula $-\frac{dI(V)}{dV} = \frac{I(V)}{V}$ will be concluded. And according to the formula of conductance $G = \frac{I}{V}$, it is need to know the instantaneous conductance and the negative conductance increment in order to get maximum power point, when the instantaneous conductance is equal to the negative conductance increment, maximum power point can be obtained. If $\frac{dP}{dV}$ is greater than 0, then the formula $\frac{dI(V)}{dV} > -\frac{I(V)}{V}$ can be deduced. In this case, to reach the

maximum power point by increasing the reference voltage is demanded. If $\frac{dP}{dV}$ is less than 0, then the formula $\frac{dI(V)}{dV} < -\frac{I(V)}{V}$, can be deduced. This method can find out the maximum power point accurately, but it requires a lot of calculation.

3.3. Fast Global Scan Algorithm

Some studies put forward a fast global scanning method [8]. The method is to scan through the current of each series of photovoltaic modules according to the local shadow of the photovoltaic array output characteristic, the approximate calculation of each peak point power size. Then the distribution interval of the maximum power point is determined. And finally, the maximum power point is found by perturbation observation and the incremental conductance method [8]. In the process of scanning photovoltaic current, accompanied by the influence of external factors, the current accuracy of the scanning process will produce errors.

3.4. Temperature measurement Method

The temperature measurement method is applicable when the influence of light on the voltage at the maximum power point of the inverter is relatively small. Assume that the maximum power point voltage is V_{MPP} , the reference temperature is T_{ref} , T is the temperature of the photovoltaic source at any time, and u is the temperature coefficient. According to formula (15), the influence of temperature on the maximum power point can be further calculated.

$$V_{MPP} = V_{MPPref} + u(T - T_{ref}) \quad (15)$$

4. Inverter control policy

As the core link of the DC power supply connecting to the grid, grid-connected inverter control has become a research hotspot, and its control performance directly affects the output power quality [10]. Aiming at the coupling relationship between inductance current and capacitance-voltage of LC grid-connected inverters, and the poor control performance of single voltage tracking targets, a multi-objective collaborative optimization model prediction strategy was proposed in some literature [7]. Another piece of literature proposed a quasi-proportional resonance (QPR) control strategy to improve the tracking performance of grid-connected current, aiming at the problem that the PI control strategy cannot achieve static error-free control of an inverter sinusoidal AC signal [11]. In order to improve the steady-state and dynamic performance of the energy storage converter during operation, other scholars proposed an improved sag control based on a phase-locked loop [12]. Currently, finite set model predictive control is widely used in power electronic systems, but it has problems such as current fluctuation, harmonic distortion, action delay and high switching loss in actual control [13]. In order to realize the no-static control of the grid-connected current of the inverter, the proportional resonance double closed-loop control strategy can make it have infinite gain at the fundamental frequency, thus improving the tracking performance of the inverter. However, if the frequency fluctuation occurs at the non-fundamental frequency, the tracking performance will decrease.

5. Conclusion

This paper reviews and analyzes the principles of four commonly used single-phase photovoltaic inverter topologies. Starting from the methods of creating an open-circuit state between the parasitic capacitance and the grid and voltage clamping, it is verified that all four inverter topologies can effectively solve the leakage current problem of the inverter.

Dc converter is an important device in the field of electronic circuits, which adjusts the duty cycle through the on-off and on-off time of the switching tube, so as to realize the flexible adjustment of DC output voltage and output power. The current DC converters are mainly divided into isolated type and non-isolated type. The non-isolated type mainly uses Buck, Boost and Buck-Boost converters, and the isolated type mainly uses Flyback, Forward, half-bridge and full-bridge converters. In the future, the realization of high efficiency and high precision maximum power control of inverters becomes one of the key directions. Researches on control strategy can focus on the control of grid-connected current of inverters without static error and the exploration of the steady and dynamic performance of the system.

References

- [1] Bao Xiyong, et al." Review of Typical Topologies and Control Strategies of Photovoltaic Inverters and DC Converters." *Journal of Shandong Electric Power College* 26.06(2023):20-24.
- [2] Gu Panpan, et al." Research Review of Grid-Connected Inverter in Photovoltaic Power Generation System." *China Electrical Engineering*, 11(2017):1-5+29."
- [3] Kang Jiayu, et al. "Research on Simulation of a Novel Single-Phase H5 Photovoltaic Grid-Connected Inverter Based on PR Controller." *appliances and management of energy efficiency technology*. 09 (2017) : 67-73. The doi: 10.16628 / j.carol carroll nki. 2095-8188.2017.09.013.
- [4] ZHAO Yazhou, et al." Study on Circuit Topology For Improved Neutral-Point-Clamped Heric." *Acta Energiæ Solaris Sinica* 42.08(2021):128-132.doi:10.19912/j.0254-0096.tynxb.2019-0516.
- [5] Liu Wei. *Research on three-level NPC inverter based on carrier modulation*.2023. Harbin engineering university, MA thesis. Doi: 10.27060 / , dc nki. Ghbcu. 2023.000222.
- [6] Zhang Gui-Chen, Chai Fang-Yang,and Zhou Jing-Hua."A T-type Three-level Inverter Neutral-point Potential Balancing Circuit and Control." *Power Electronics* 58.02(2024):123-126.
- [7] Wang Yukun, and Chen WoYuan. "bipolar type photovoltaic inverter based on disturbance observation MPP T optimization strategy." *information recording materials* 19.06 (2018) : 11-13. Doi: 10.16009 / j.carol carr oll nki cn13-1295 / tq. 2018.06.005.
- [8] Gao yuan. *Research on Maximum Power Point Tracking Technology of Photovoltaic System*. "2020. Southwest jiaotong university, MA thesis. Doi: 10.27414 / , dc nki. Gxnju. 2020.000392.
- [9] Lai Qitao, and Wang Yuanyue. "Design of PV Array Failure Module Monitoring System Based on Temperature Measurement." *Computer measurement & control* of 25.05 (2017) : 38-41. Doi: 10.16526 / j.carol carroll nki. 11-4762 / tp. 2017.05.012.
- [10] Quan Xinbo, Hu wei, and Fang shilei. "Multi-objective Co-optimization Model Predictive Control Strategy of LC Grid-connected Inverters." *Automation & Instrumentation* 40.01 (2025) : 17-22. Doi: 10.19557 / j.carol carroll nki. 1001-9944.2025.01.004.
- [11] Zhang Xiaofeng, et al. "Quasi-proportional Resonance Control of the Single LCL Grid-connected Inverter." *Journal of Mianyang Teachers' College(Science)* 44.02 (2025) : 42-49. Doi: 10.16276 / j.carol carroll nki cn51-1670 / g. 2025.02.006.
- [12] Zhao Changle, et al. "Research on Improved Droop Control Strategy Based on Power Conversion System." *Power Electronics* 58.12 (2024) : 69-73 + 77, doi: 10.20222 / j.carol carroll nki cn61-1124 / tm. 2024.12.018.
- [13] Wang Zilin. *Research on finite-control-set model predictive control of NPC Inverter*. 2023. Harbin Institute of Technology, MA thesis. Doi: 10.27061 / , dc nki. Ghgdu. 2023.001215.